

MOTOR- UND KRÜMMERSCHUTZ

Engine and manifold protection | Protector de motor y tubo acodado | Pare-cylindres et protection de collecteur | Protezione del motore e dei collettori

Art.-Nr: 26850-30X

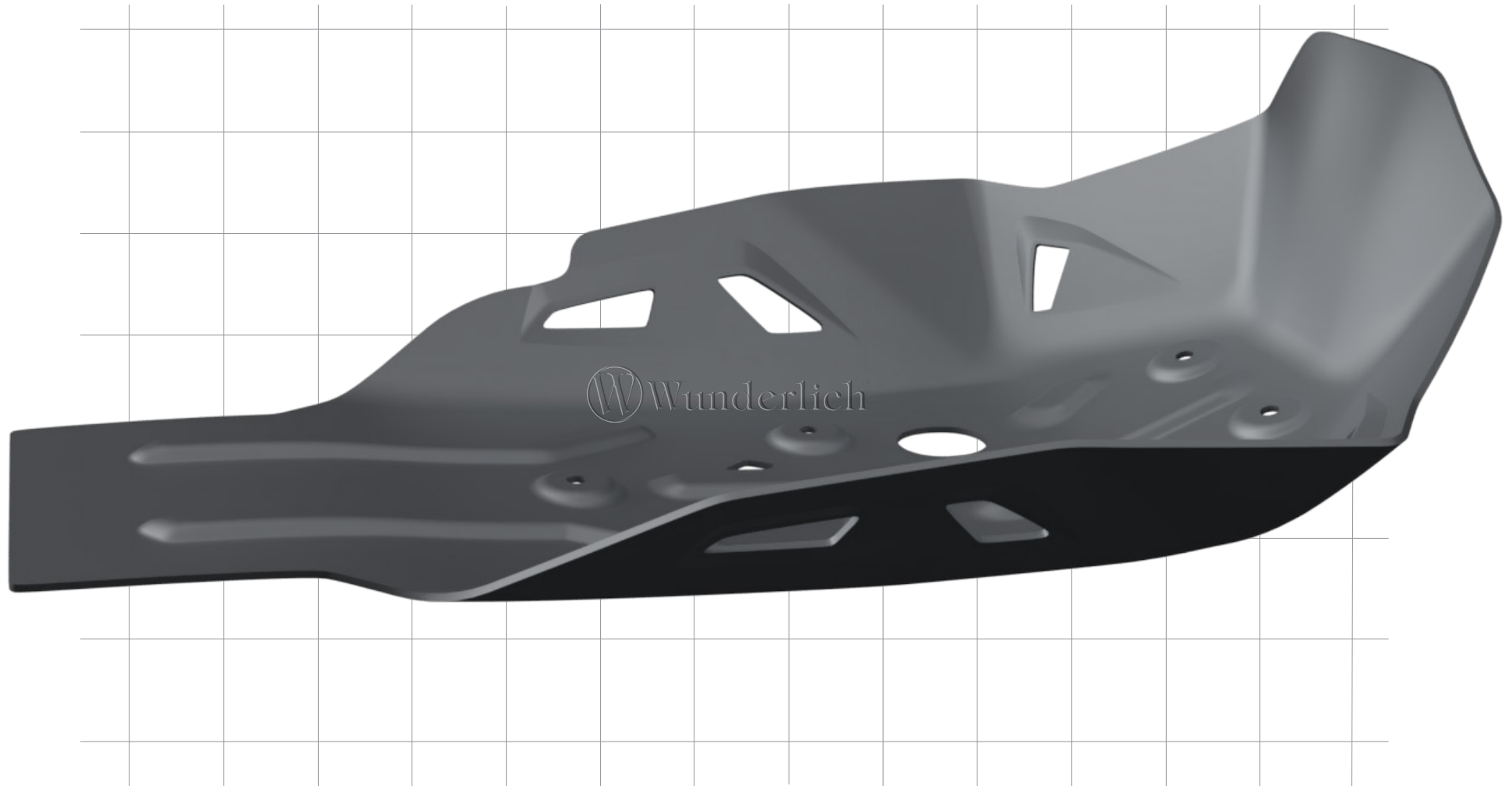

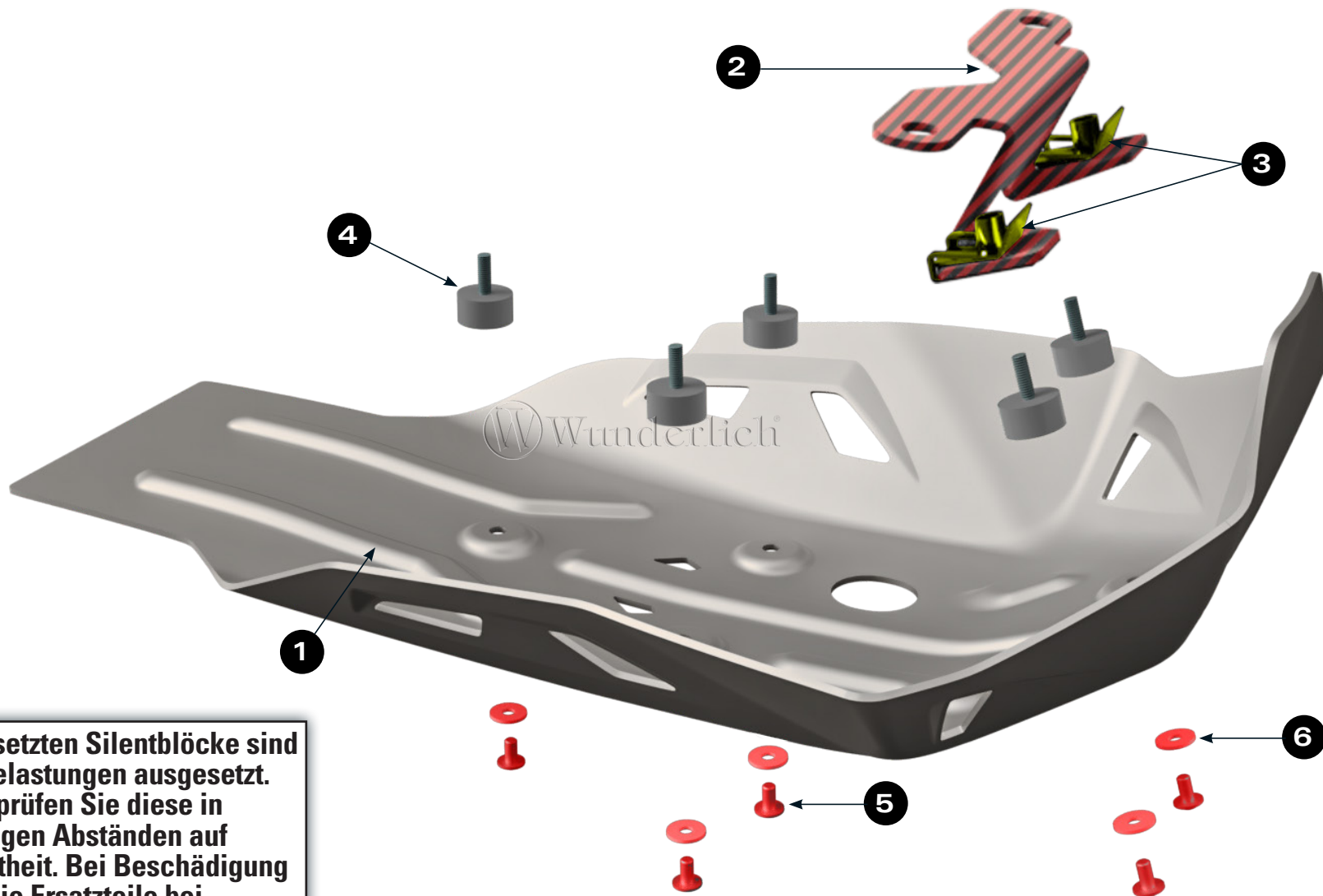

Die eingesetzten Silentblöcke sind starken Belastungen ausgesetzt. Bitte überprüfen Sie diese in regelmäßigen Abständen auf unversehrtheit. Bei Beschädigung erhalten Sie Ersatzteile bei unserem Kundensevice.

The fitted rubber grommets are exposed to strong pressures. Please check the rubber grommets regularly for intactness. If the rubber grommets are damaged please get in contact with our customer service here at Wunderlich to get some spare grommets.

#	BEZEICHNUNG / DESCRIPTION	DIN	ISO	MENGE AMOUNT
1	Motor- und Krümmerschutz / Engine and manifold protection			1
2	Halter (vorne) / holder			1
3	Blechmutter / sheet-metal nut			2
4	Silent Block / rubber grommet			5
5	Linseflanschschraube M6 x 12 / lenshead screw		7381	5
6	Unterlegscheibe M6 / washer	125	7089	5

LEGENDE / KEY

-  Anbau Tipp / Fitting tip
-  Achtung / Attention
-  Vergrößerung / Magnification

 Schraube / Screw

 Schraubensicherung / Thread locking fluid

 Drehmoment / Torque

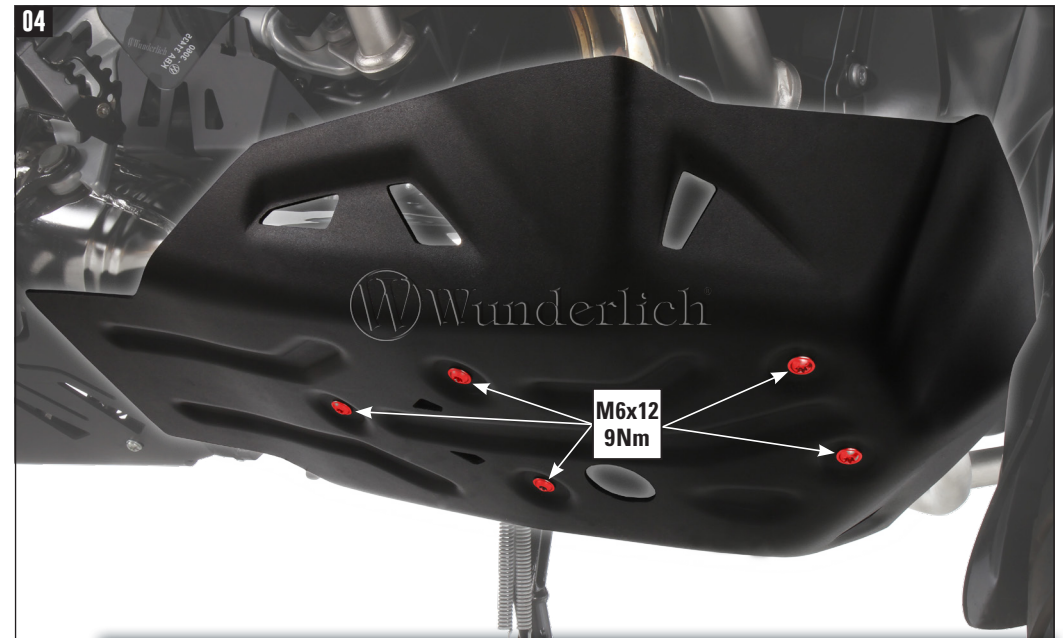

! Schrauben regelmäßig auf festen Sitz prüfen und gegebenenfalls nachziehen!
Check bolts regularly for tightness and retighten if necessary!