

# SCHUTZPAD

Slide pad | Almohadilla antiarañazos | Patin de ponçage | Tampone scorrevole

Art.-Nr: **35831-2XX**



**LINKE SEITE**  
Left side  
côté gauche

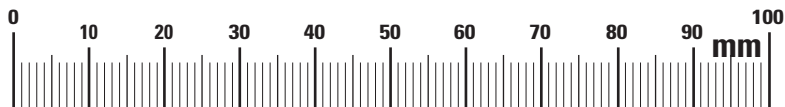
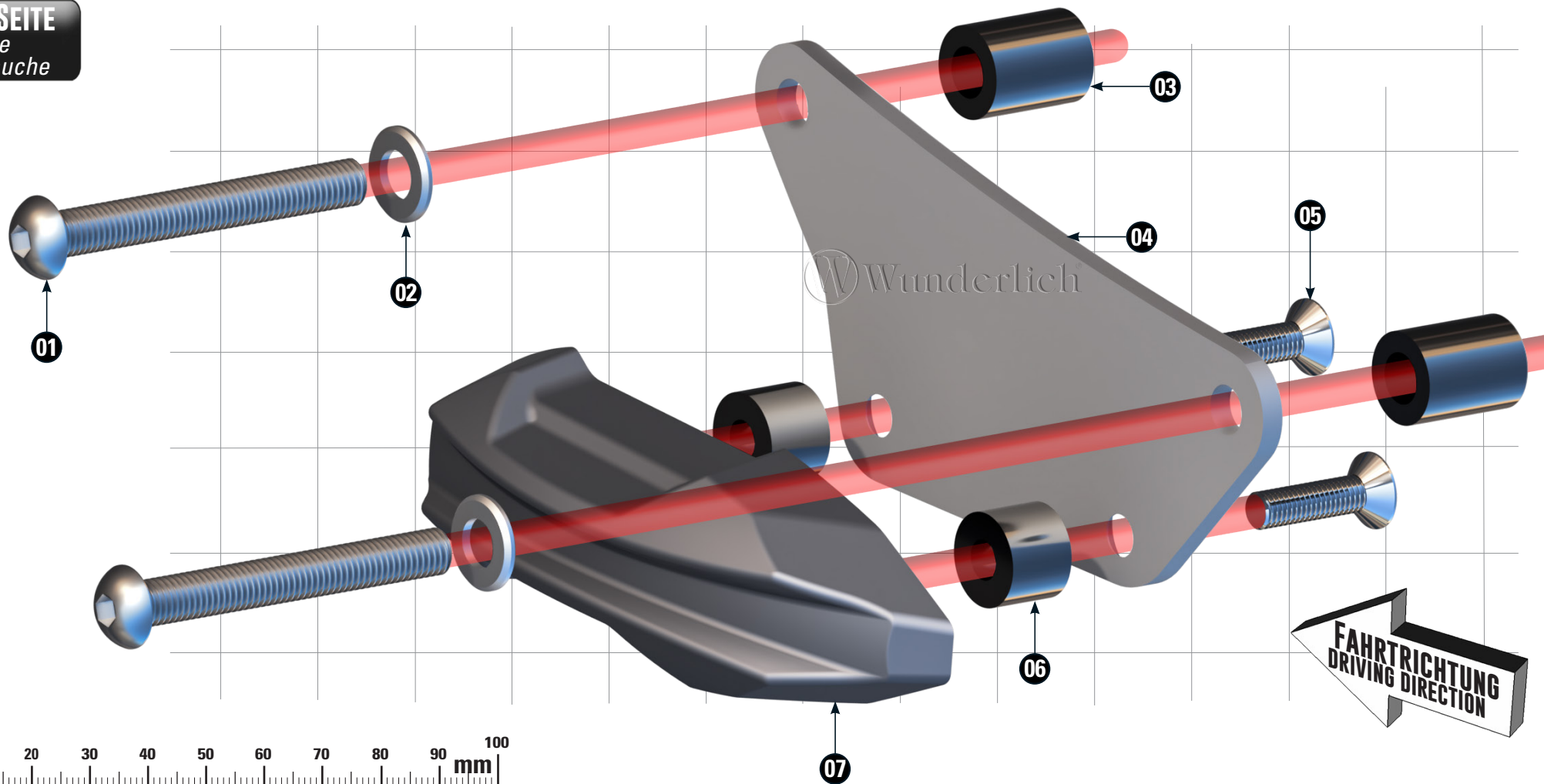

#	BEZEICHNUNG / DESCRIPTION	DE EN FR	Die Farben der Abbildungen dienen nur der Veranschaulichung. The colors are for illustrating purposes only. Les couleurs utilisées sont à titre indicatif seulement.	DIN	ISO	MENGE QUANTITY
1	Linsenkopfschraube / lens head screw	M10 x 80		7380Z10.9	7380Z10.9	2
2	U-Scheibe / Washer	M10		125Z	125Z	2
3	Hülse / Sleeve	DØ 19,6 - dØ 10,8 - h 25,0mm				2
<b>4-7 Vormontiert / 4-7 Pre-assembled</b>						
4	Tragblech / Supporting plate					1
5	Senkkopfschraube / Countersunk screw	M8 x 30		7991A2	7991A2	2
6	Hülse / Sleeve	DØ 20,0 - dØ 8,5 - h 15,0mm				2
7	Schutzpad linke Seite / Pad left side					1

LEGENDE/KEY/FILE LÉGENDE

- Anbau Tipp**  
Fitting tip  
Astuce de montage
- Achtung**  
Attention  
Attention
- Vergößerung**  
Magnification  
Grossissement
- Montagepaste**  
Fitting lubricant  
Lubrifiant de montage

- Schraube**  
Screw  
Vis
- Schraubensicherung**  
Thread locking fluid  
Freiniflets
- Drehmoment**  
Torque  
Torque
- Reiniger**  
Cleaner  
Nettoyant

**RECHTE SEITE**  
*Right side*  
*Côté droit*

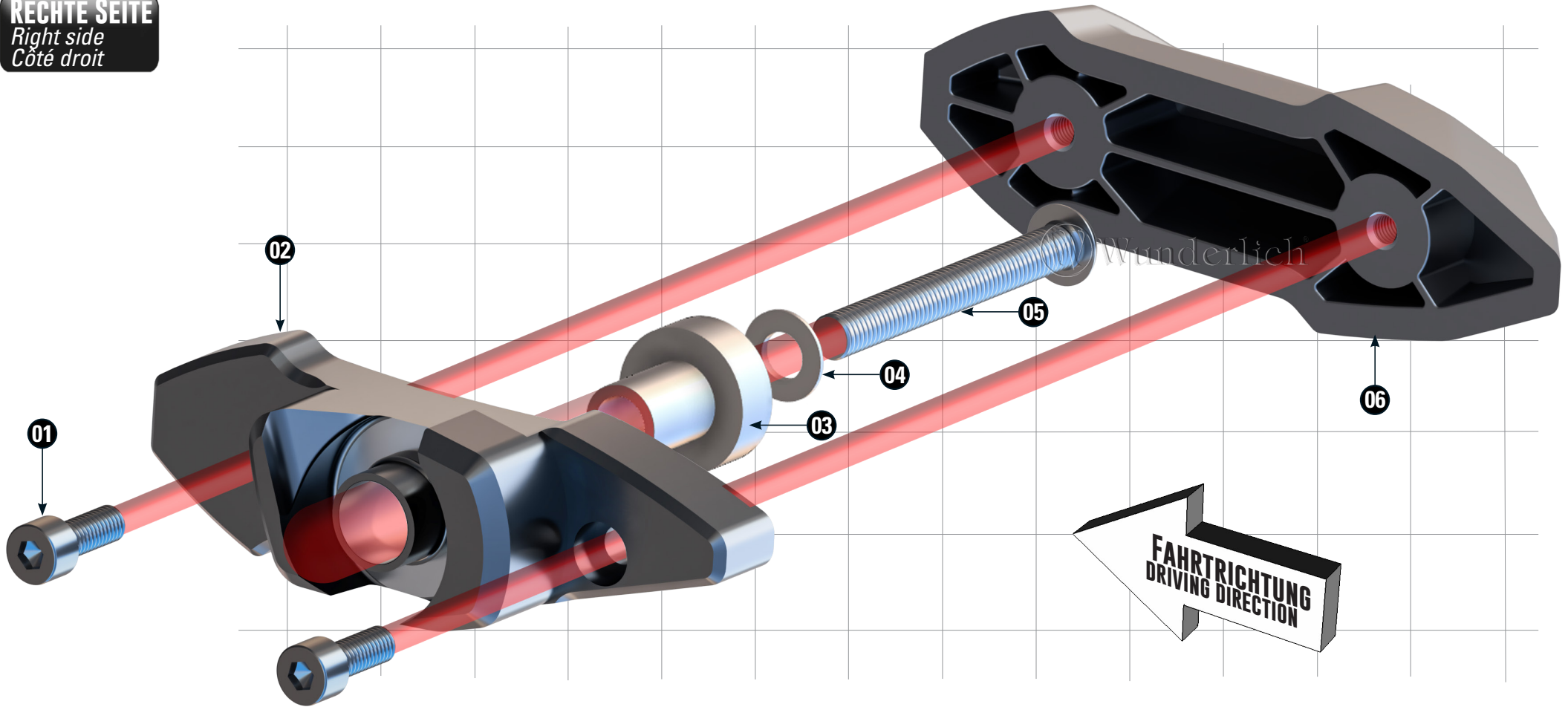

#	BEZEICHNUNG / DESCRIPTION	DE Die Farben der Abbildungen dienen nur der Veranschaulichung. EN The colors are for illustrating purposes only. FR Les couleurs utilisées sont à titre indicatif seulement.	DIN	ISO	MENGE QUANTITY
1	Zylinderkopfschraube / cylinder head screw	M8 x 20	912A2	912A2	2
2	Verbinder / Connector				1
3	Stufenhülse / Grade sleeve				1
4	U-Scheibe / Washer	M10	125Z	125Z	1
5	Linsenkopfschraube / lens head screw	M10 x 80	7380Z10.9	7380Z10.9	1
6	Schutzpad rechte Seite / Pad right side				1



01

**LINKE SEITE**Left side  
côté gauche**DREHMOMENTE NM, ANZIEHREIHENFOLGE**

Torques Nm, sequence | Couples Nm, séquence

1: links an Rahmen  
left to frame | de gauche à droite**60 NM**2: rechts an Rahmen  
left to frame | droit au cadre1. **30 NM**

2. Weiterdrehwinkel, 90°

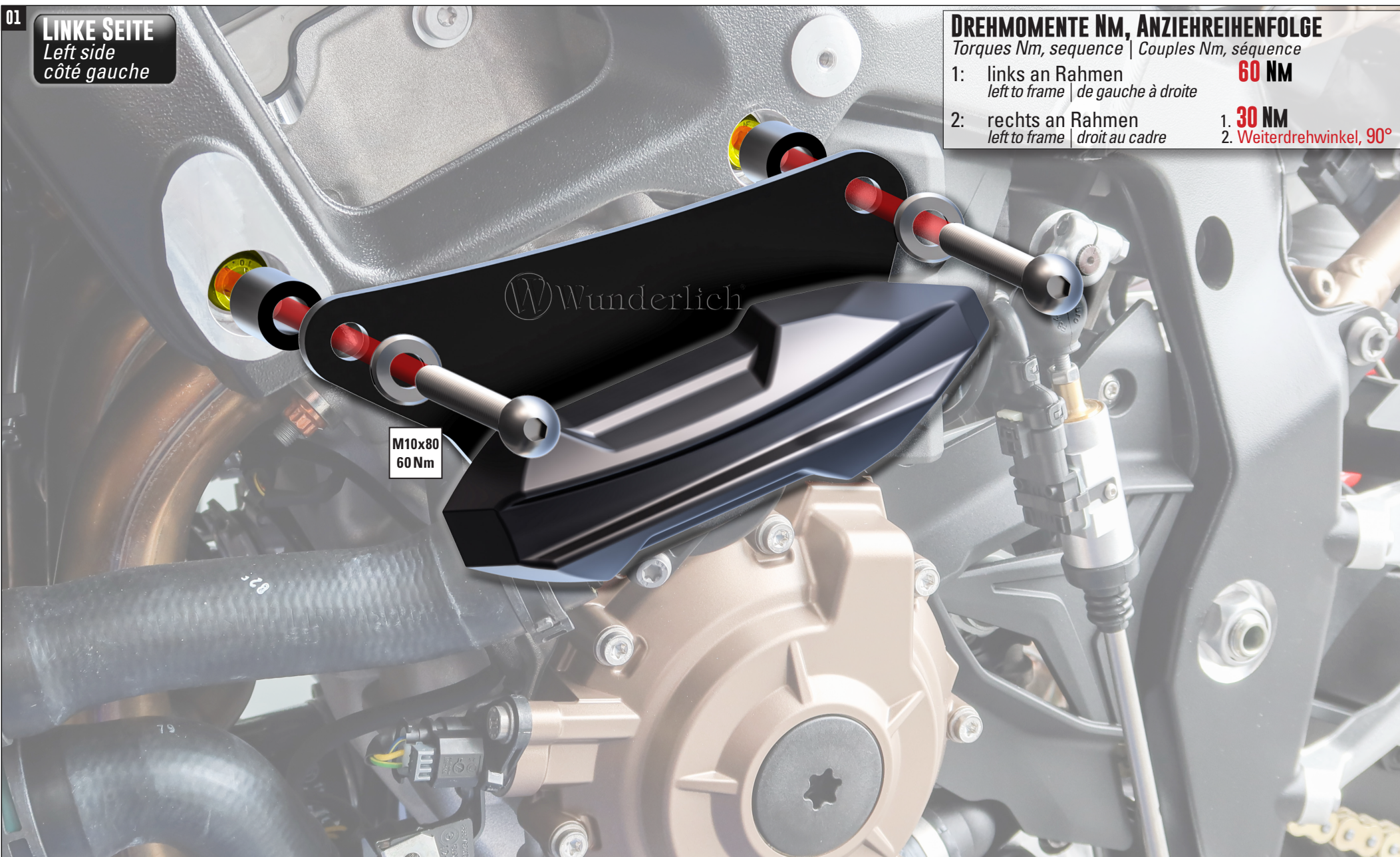
M10x80  
60 Nm**SCHRAUBEN DER LINKE SEITENVERKLEIDUNG MÜSSEN NUR GELÖST WERDEN. GEGEBENENFALLS WIE DIE RECHTE SEITE DEMONTIEREN!**

Screws of the left cover panel only need to be loosened! If necessary, dismantle like the right side!

Il suffit de desserrer les vis du panneau de recouvrement gauche. Si nécessaire, démontez comme le côté droit !







06

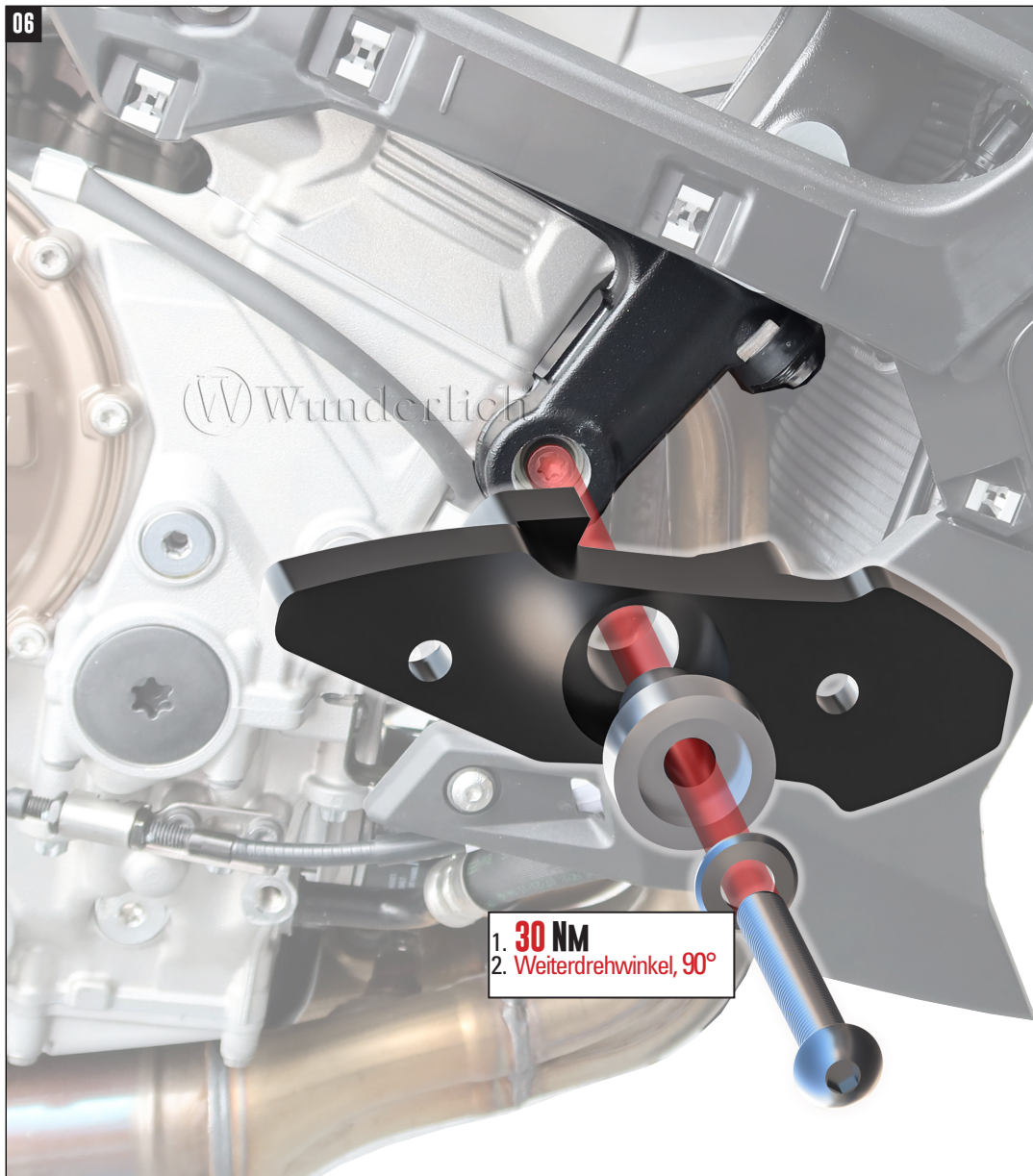

07

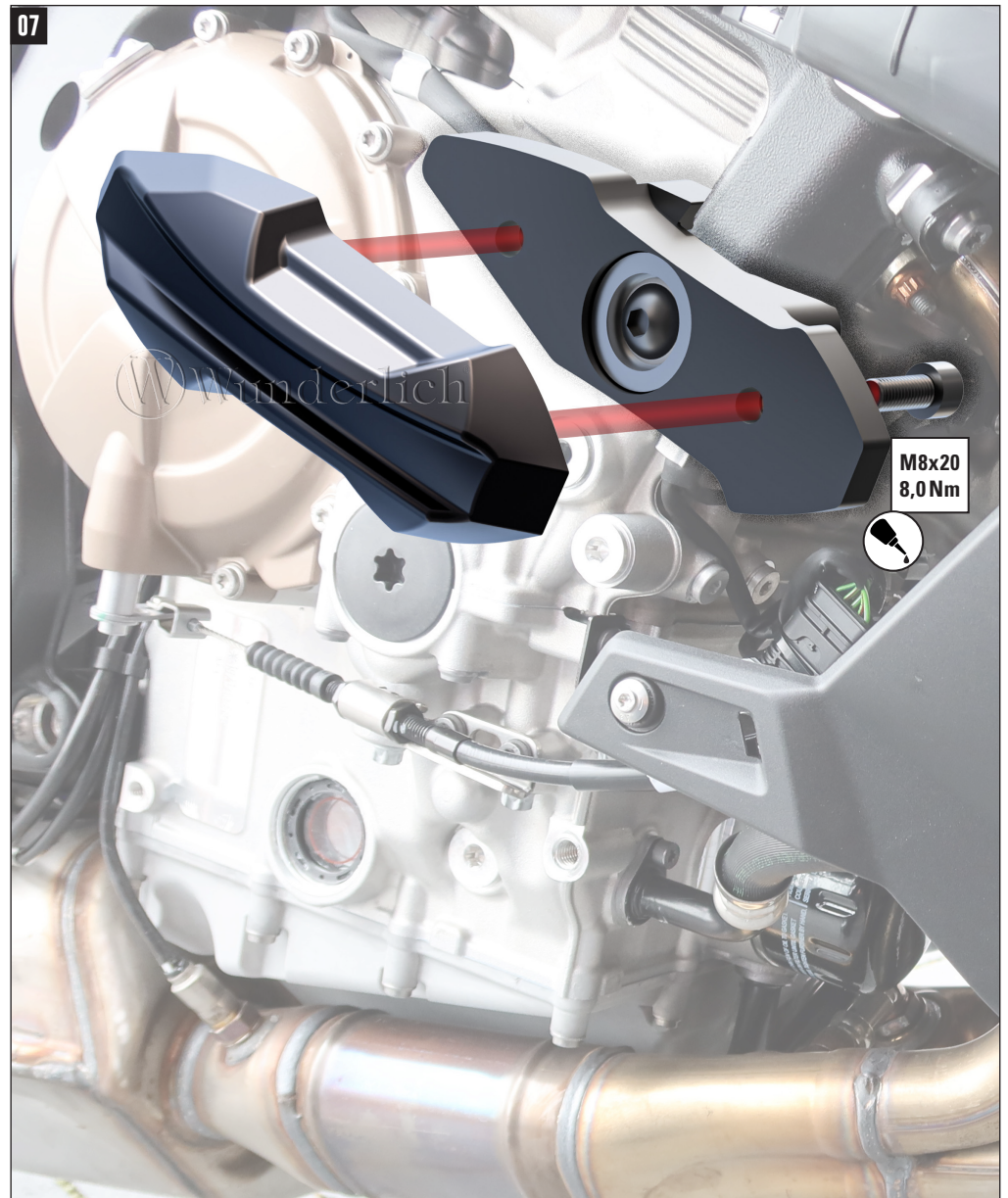

### SEITENVERKLEIDUNG NACH DER MONTAGE DES SCHLEIFPADS, IN UMGEKEHRTER REIHENFOLGE ANBAUEN!

After fitting the slide pad, mount the side panel in reverse order.

Après avoir monté le patin de glissement, montez le panneau latéral dans l'ordre inverse!