

ABDECKUNG EINSPRITZANLAGE, SET

Injector cover set | Capots de système d'injection | Cubiertas de inyección | Coperture del sistema di iniezione

Art.-Nr: 42940-602/612

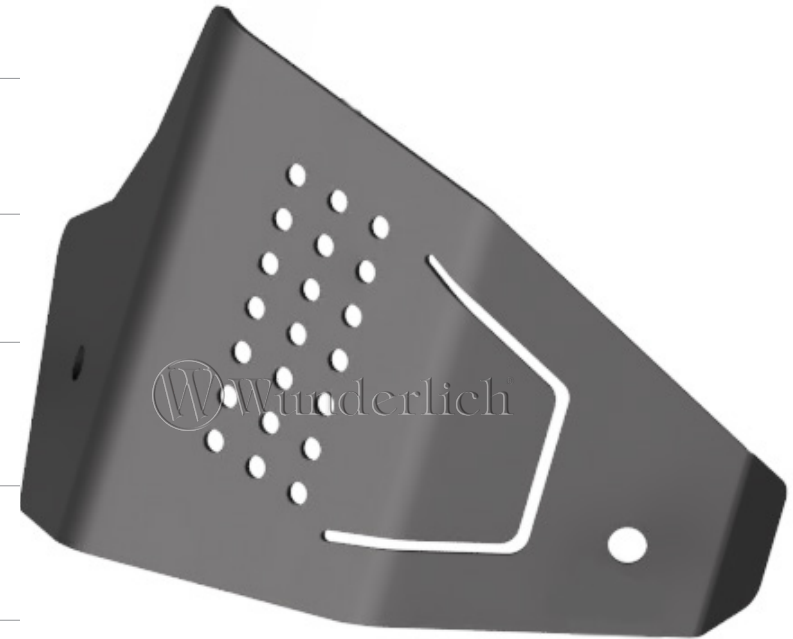

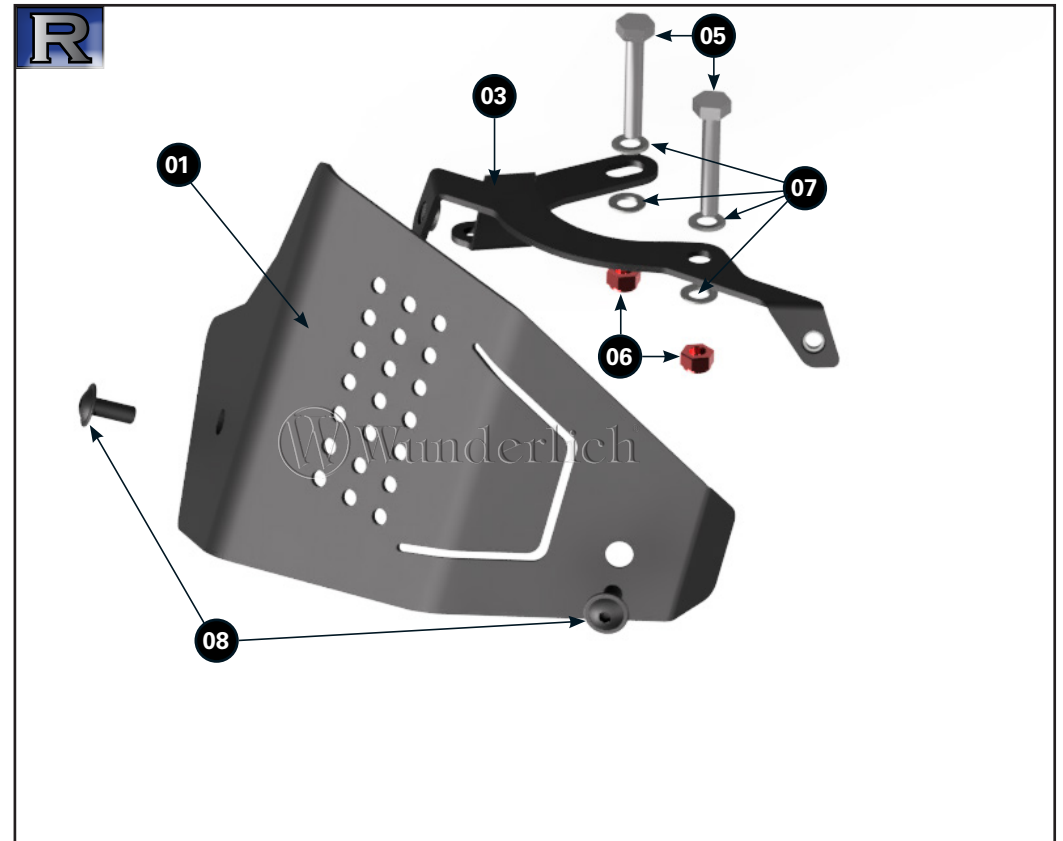
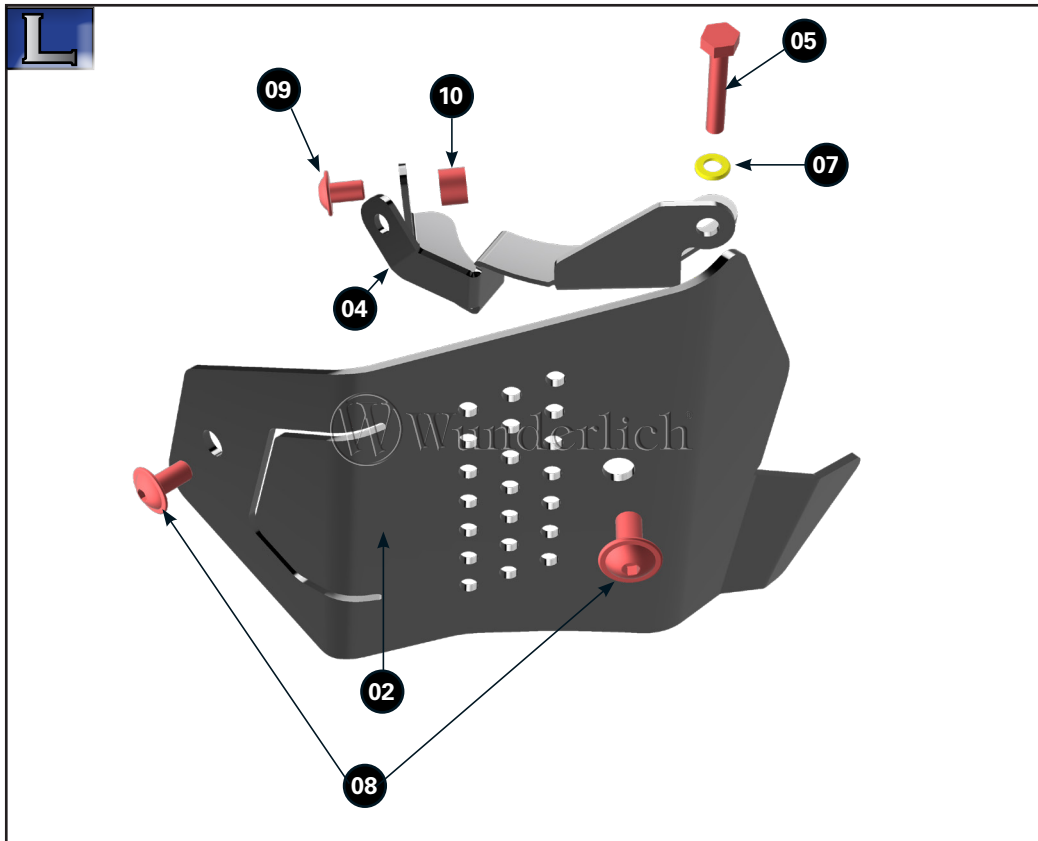

#	BEZEICHNUNG	MENGE
1	Abdeckung Einspritzanlage (rechts)	1
2	Abdeckung Einspritzanlage (links)	1
3	Halter (rechts)	1
4	Halter (links)	1
5	Sechskantschraube M5 x 30	3
6	Sechskantmutter (selbstsichernd) M5	3
7	Unterlegscheibe M5	6
8	Linsenflanschschraube M5 x 10 (schwarz)	4
9	Linsenflanschschraube M6 x 10	1
10	Gewindehülse M6 (8 mm)	1
11	Kabelbinder	2

LEGENDE / KEY



Anbau-Tipp
Fitting tip



Schraube
Screw



Achtung
Attention



Schraubensicherung
Thread locking fluid



Vergrößerung
Magnification



10x14
Nm Drehmoment
Torque



Montagepaste
Fitting lubricant

