

TANKSCHUTZBÜGEL ULTIMATE

Protection bar | Protección de Tanque | Protection de réservoir | Protezione del serbatoio

Art.-Nr: 13210-002

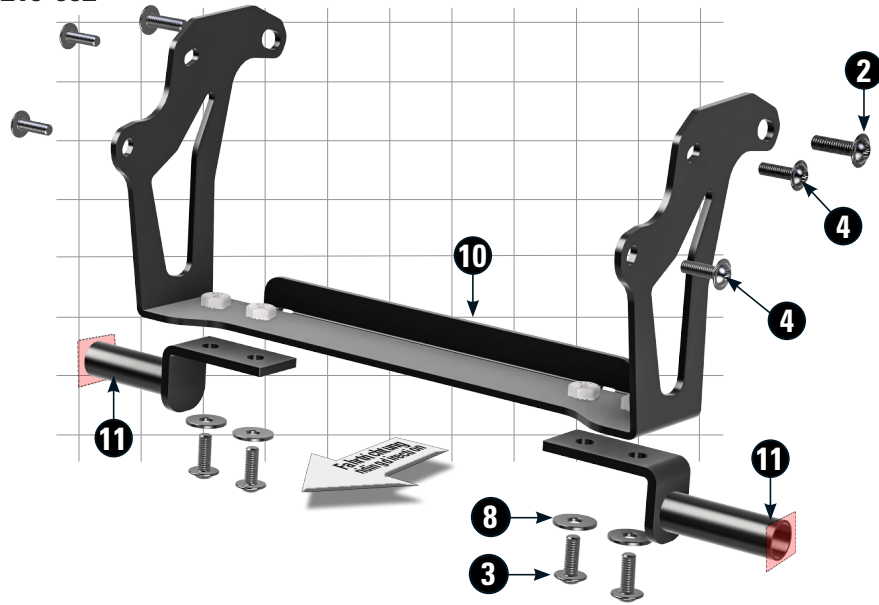

#	Bauteil component composant	DE Die Farben der Abbildungen dienen nur der Veranschaulichung. EN The colors are for illustrating purposes only. FR Les couleurs utilisées sont à titre indicatif seulement.	DIN	ISO	Menge quantity quantité
1	Zylinderschraube (schwarz) / Cylinder screw (black)	M8x65 (Torx)	912SZ	4762	2
2	Linsenflanschschraube (schwarz) / Lens head screw (black)	M6x30 (Torx)	7381	7381	2
3	Linsenflanschschraube (schwarz) / Lens head screw (black)	M6x16 (Torx)	7381	7381	4
4	Linsenflanschschraube (schwarz) / Lens head screw (black)	M5x16 (Torx)	7381	7381	4
5	Alu-Distanzhülse (schwarz eloxiert) / Alu sleeve (black anodized)	ØD 22,0 - Ød 10,5 - h 5,0 mm			1
6	Alu-Distanzhülse (schwarz eloxiert) / Alu sleeve (black anodized)	ØD 22,0 - Ød 10,5 - h 10,0 mm			1
7	U-Scheibe (schwarz) / Washer (black)	M8	9021SA2	7093	2
8	U-Scheibe (schwarz) / Washer (black)	M6	9021SA2	7093	4
9	Rohrstopfen / Pipe plugs				2
10	Schnabelhalter / Beak bracket				1
11	Rechter & linker Schutzbügel / Right & left crash protect				2
12	Schraubensicherung / Thread locking fluid				1

LEGENDE/KEY/FILE LÉGENDE

- Anbau Tipp**
Fitting tip
Astuce de montage
- Achtung**
Attention
Attention
- Vergrößerung**
Magnification
Grossissement
- Montagepaste**
Fitting lubricant
Lubrifiant de montage

- Schraube**
Screw
Vis
- Schraubensicherung**
Thread locking fluid
Freinfilets
- Drehmoment**
Torque
Torque
- Reiniger**
Cleaner
Nettoyant

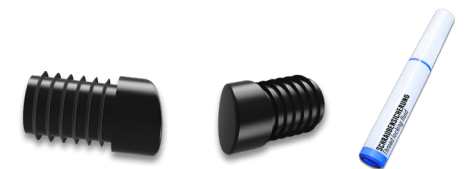

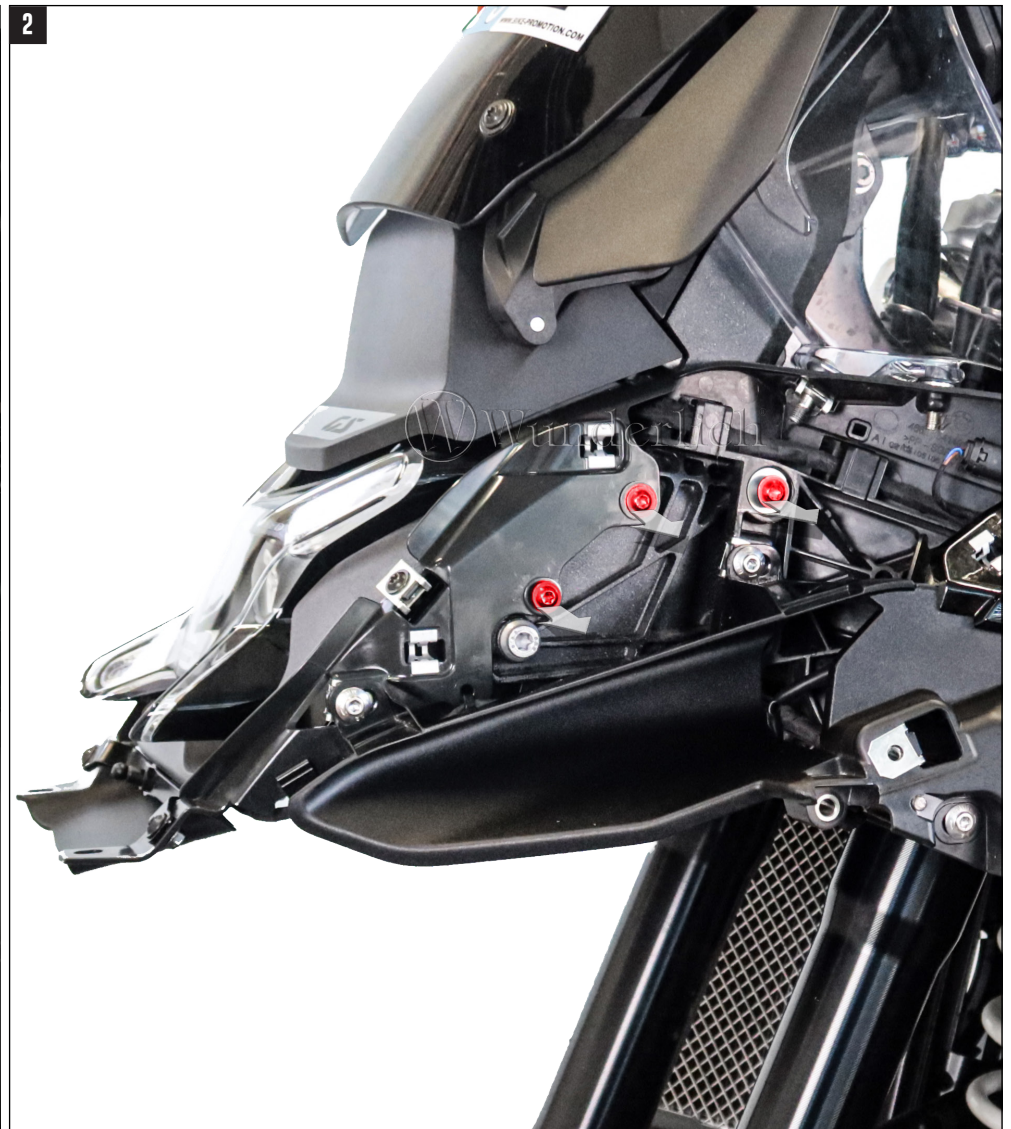

Vorderradabdeckung oben demontieren. Siehe Betriebsanleitung-BMW.
Remove the top front wheel cover. See BMW operating instructions.
Retirer l'enjoliveur de roue avant supérieur. Voir les instructions d'utilisation de BMW.

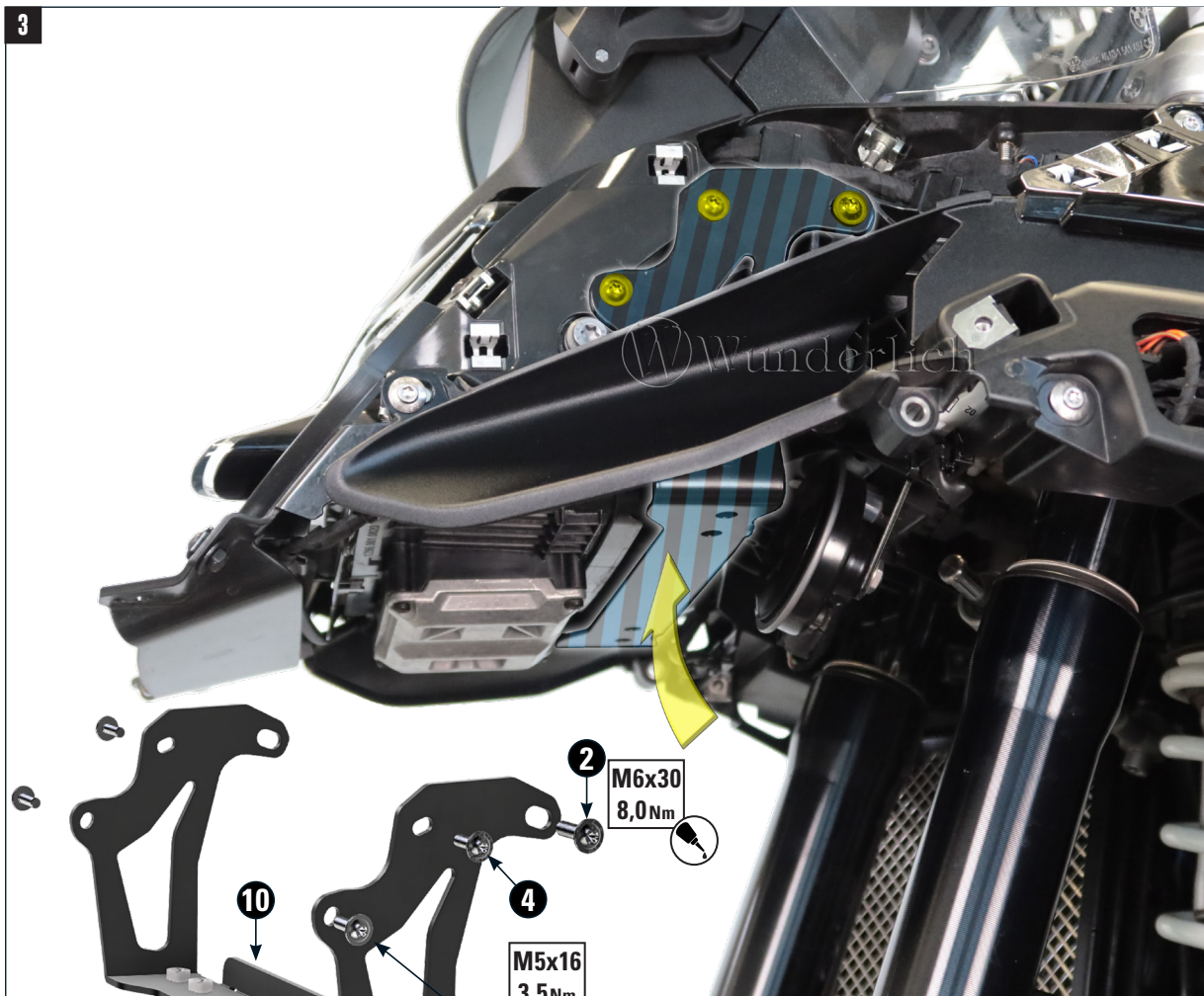

Schnabelhalter lose vormontieren und erst nach der Bügel Montage festziehen.
Pre-fit the beak holder loosely and only tighten it after the crash bar has been fitted.
Prémontier le porte-bec sans le serrer et ne le resserrer qu'après avoir monté l'arceau de sécurité.



!
In Kombination mit Lampenschutz Artikel Nr. 13260-XXX.
In combination with headlight guard Part No. 13260-002.
En combinaison avec la protection des phares Part No. 13260-002



IN KOMBINATION MIT MOTORSCHUTZBÜGEL
IN COMBINATION WITH CRASH BARS

ARTIKEL NR./PART No.: **13201-00X ULTIMATE**



M8x65
24Nm

1

7

IN KOMBINATION MIT MOTORSCHUTZBÜGEL
IN COMBINATION WITH CRASH BARS

ARTIKEL NR./PART No.: **13202-00X GUARD**



M8x65
24Nm

1

7

5

ØD 22,0 - Ød 10,5 - h 5,0 mm

8

3

M6x16
8Nm

9

Vorderradabdeckung oben nach BMW - Betriebsanleitung montieren.

Install the front wheel cover according to the BMW operating instructions.

Installer l'enjoliveur de roue avant conformément aux instructions d'utilisation de BMW.



M6x16
8Nm

IN KOMBINATION MIT MOTORSCHUTZBÜGEL
IN COMBINATION WITH CRASH BARS

ARTIKEL NR./PART NO.: **13201-00X ULTIMATE**
13202-00X GUARD

ØD 22,0 - Ød 10,5 - h 10,0 mm

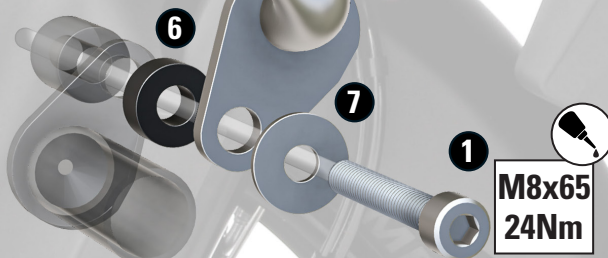

M8x65
24Nm

Vorderradabdeckung oben nach BMW - Betriebsanleitung montieren.

Install the front wheel cover according to the BMW operating instructions.

Installer l'enjoliveur de roue avant conformément aux instructions d'utilisation de BMW.

