

DAYRON

Art.-Nr: 28395-1XX

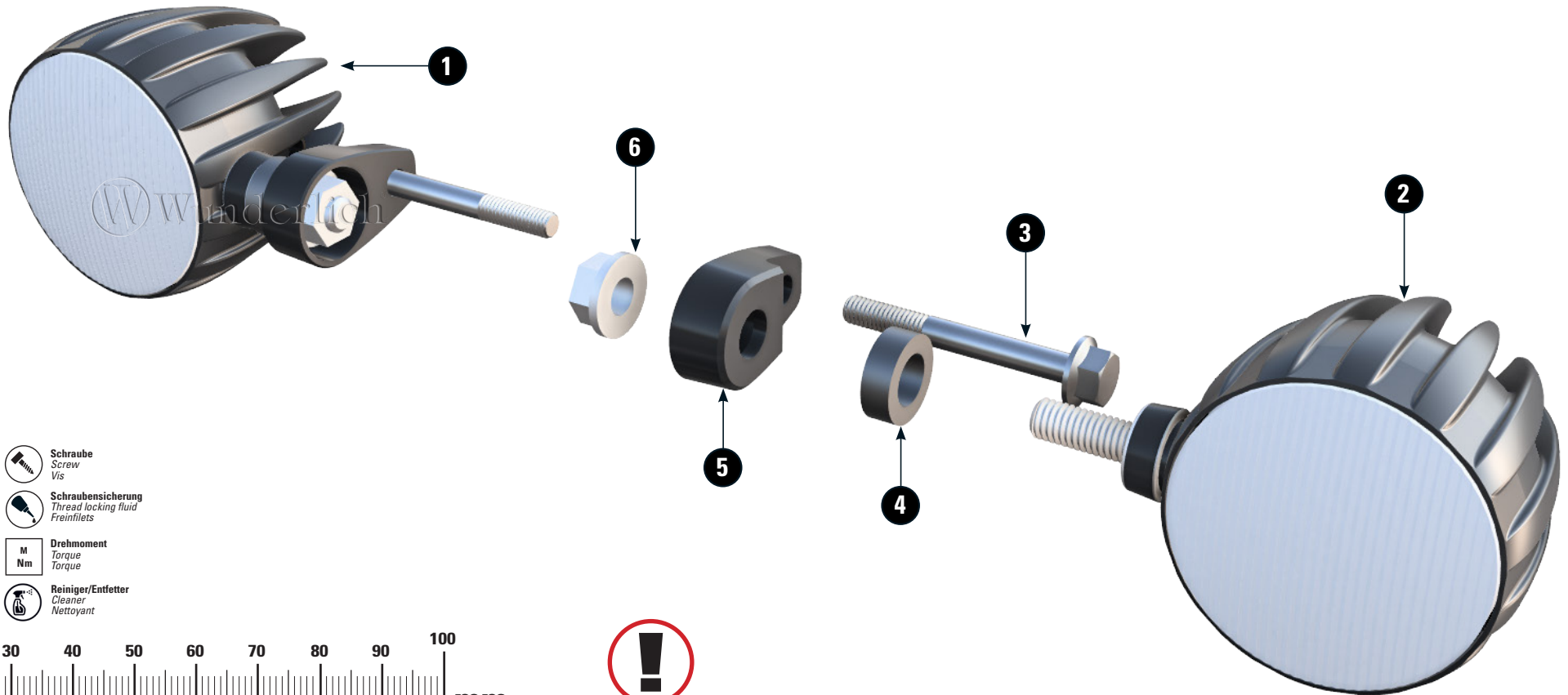

LEGENDE/Key/file Légende

- Anbau Tipp**
Fitting tip
Astuce de montage
- Achtung**
Attention
Attention
- Vergößerung**
Magnification
Grossissement
- Montagepaste**
Fitting lubricant
Lubrifiant de montage

- Schraube**
Screw
Vis
- Schraubensicherung**
Thread locking fluid
Freiniflets
- Drehmoment**
Torque
Torque
- Reiniger/Entfetter**
Cleaner
Nettoyant

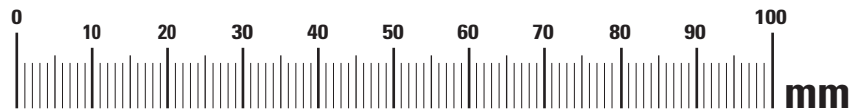

Die Montage der Dayron Scheinwerfer erfordert Fachkenntnisse und darf nur von ausgebildetem Fachpersonal ausgeführt werden. Vor der Installation, müssen alle Meldungen aus dem Fehlerspeicher gelöscht bzw. behoben werden.

The assembly of Dayron headlights requires expertise and may only be performed by trained professionals.

Before installation, all messages from the error memory must be deleted or rectified.

Le montage des phares Dayron requiert une certaine expertise et ne peut être effectué que par des professionnels qualifiés.

Avant l'installation, tous les messages de la mémoire des erreurs doivent être effacés ou rectifiés.

#	Bauteil component composant	DE Die Farben der Abbildungen dienen nur der Veranschaulichung. EN The colors are for illustrating purposes only. FR Les couleurs utilisées sont à titre indicatif seulement.	DIN	ISO	Menge quantity quantité
1	Dayron Scheinwerfer (rechts) / Dayron headlight (right side)				1
2	Daron Scheinwerfer (links) / Dayron headlight (left side)				1
3	Sechskantschraube / Hex bolt M6x50		6921	8102	2
4	Hülse / Sleeve 6mm				2
5	Adapter / Adapter				2
6	Sechskantmutter / Hex nut M8				2
7	Kabelbaum / wiring harness				1

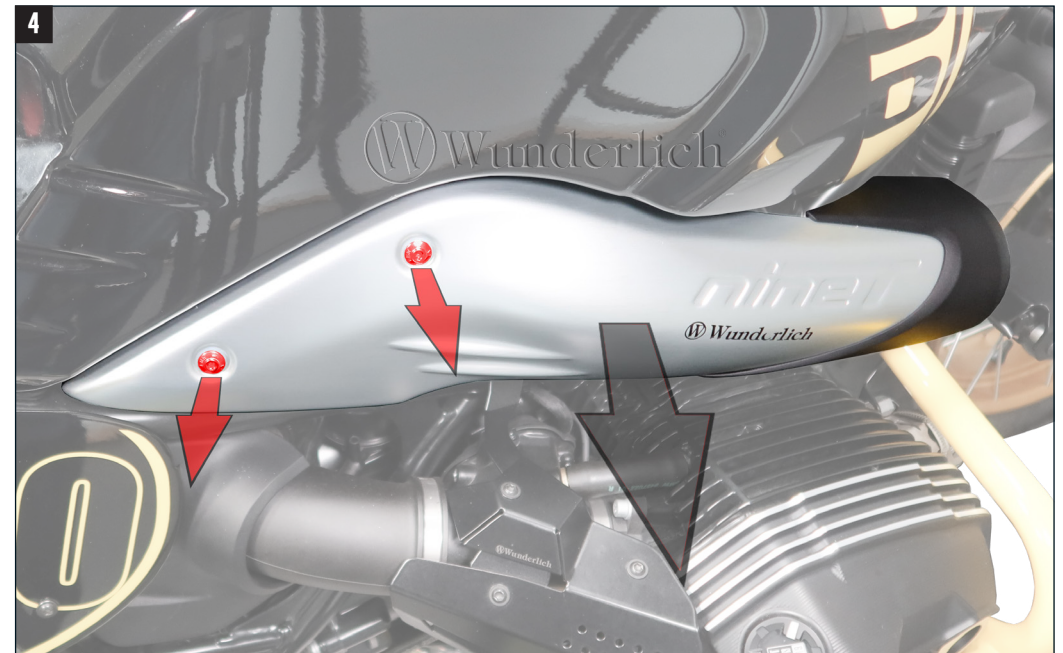

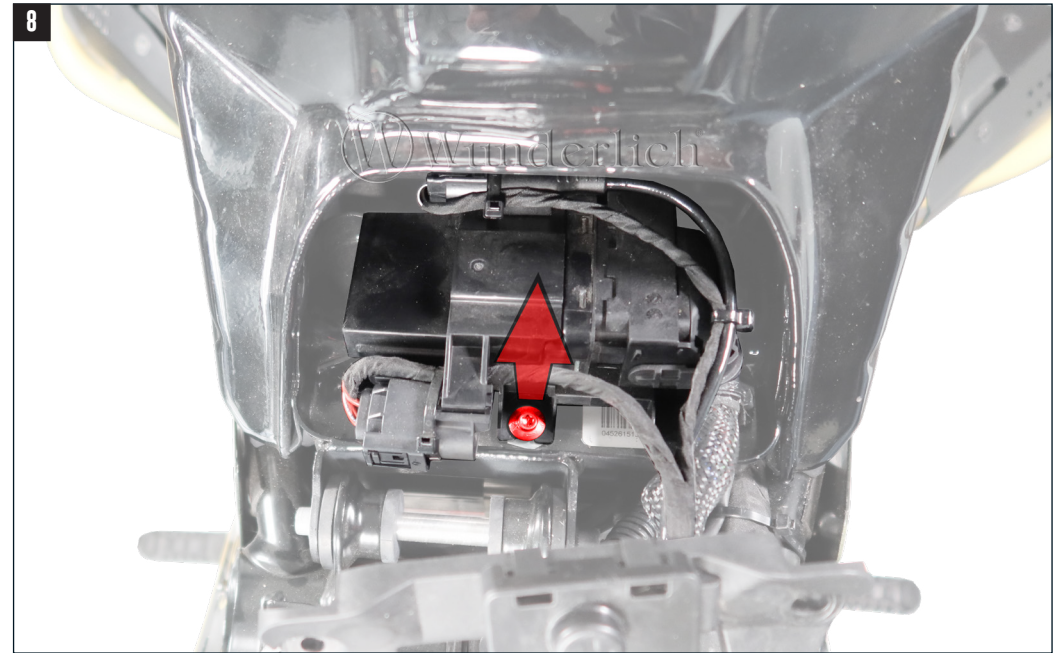
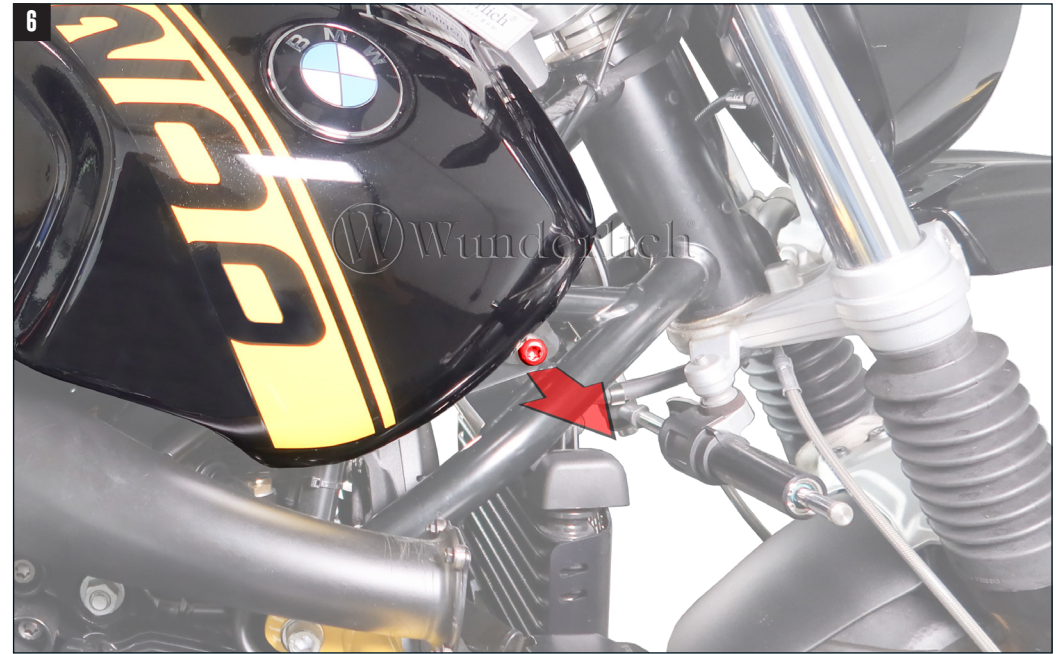
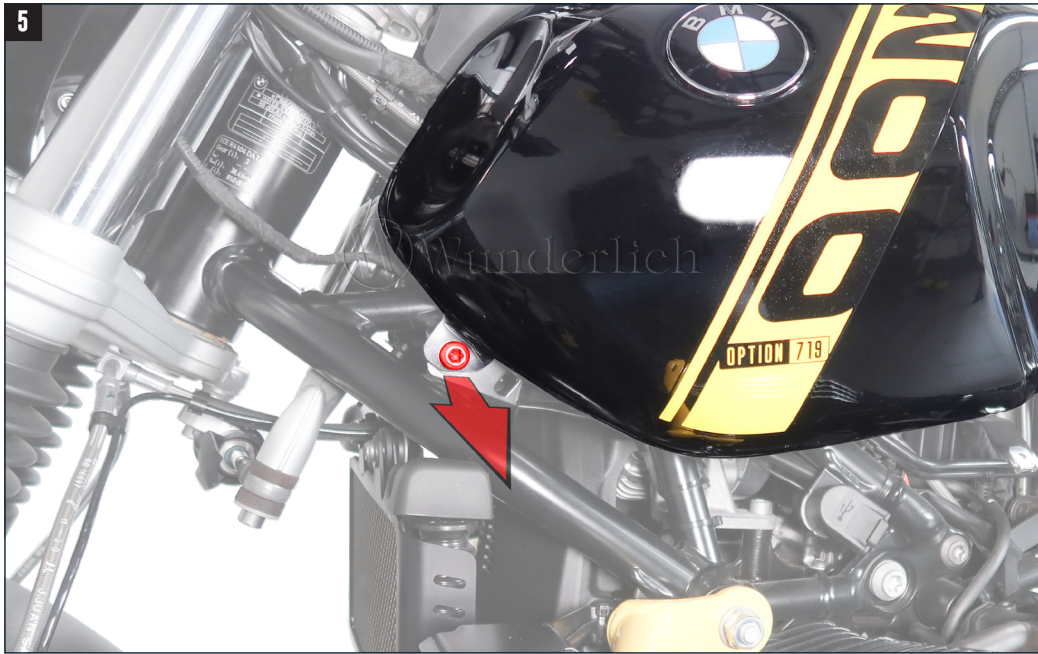

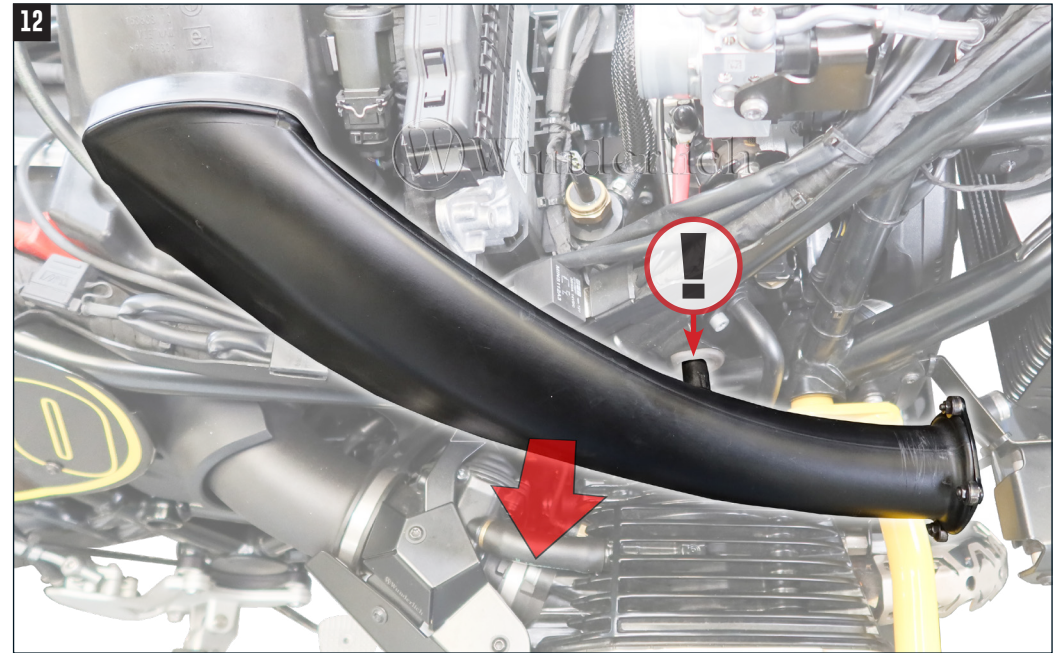
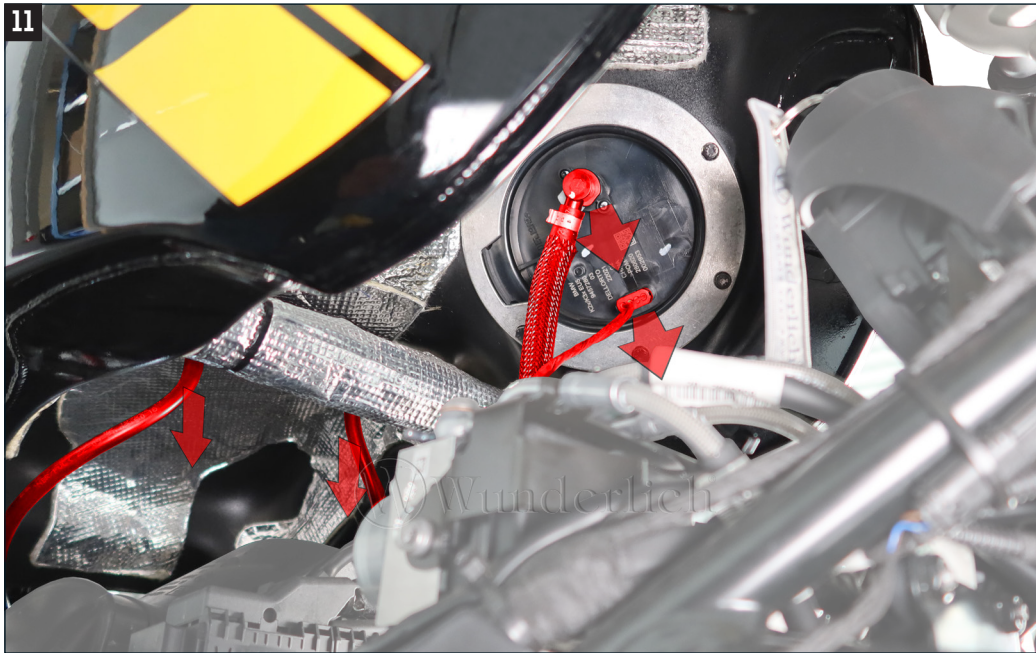
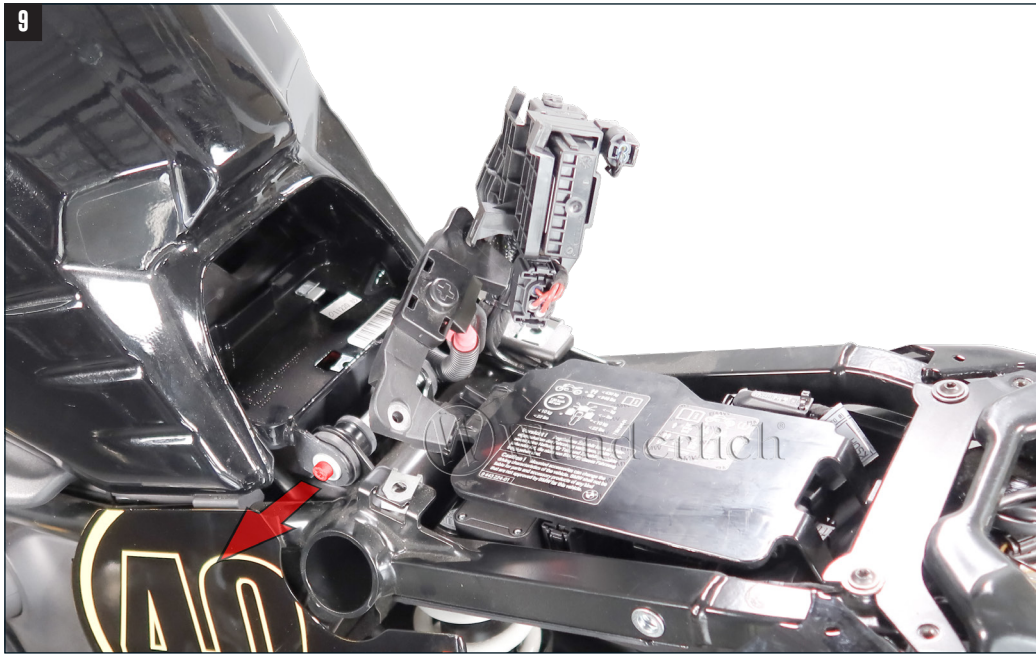

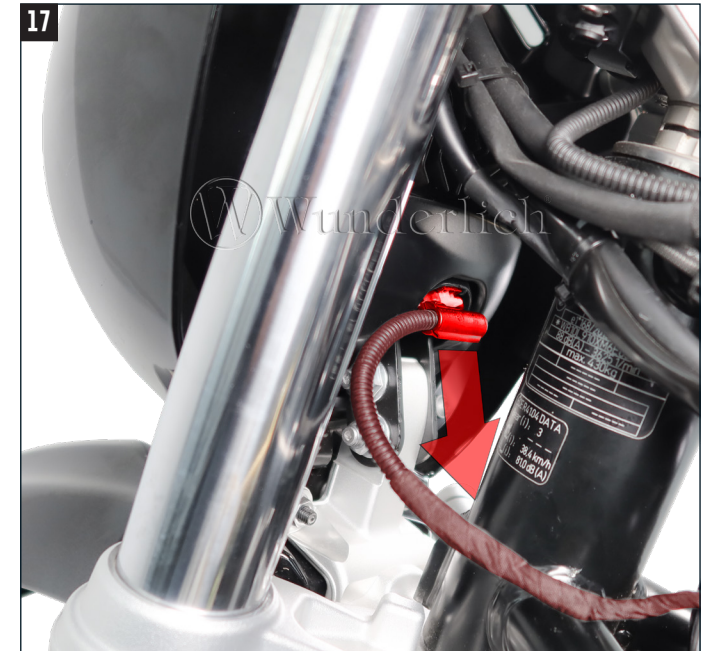
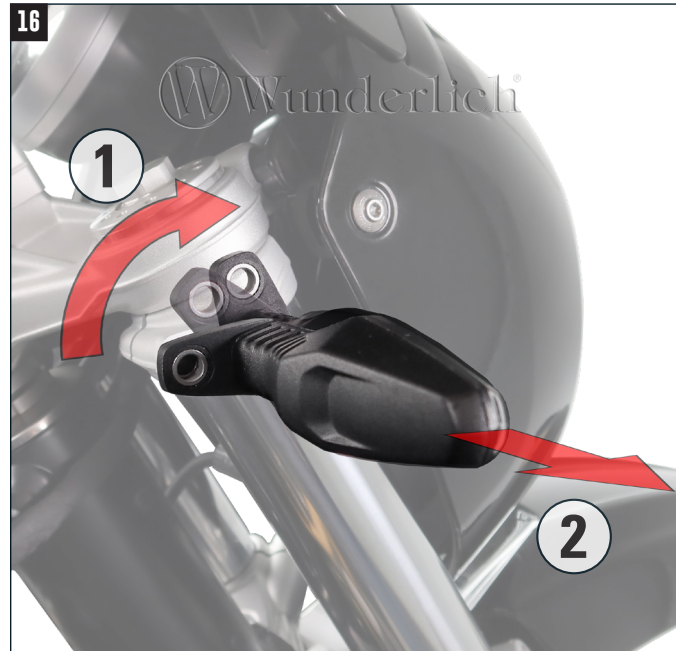
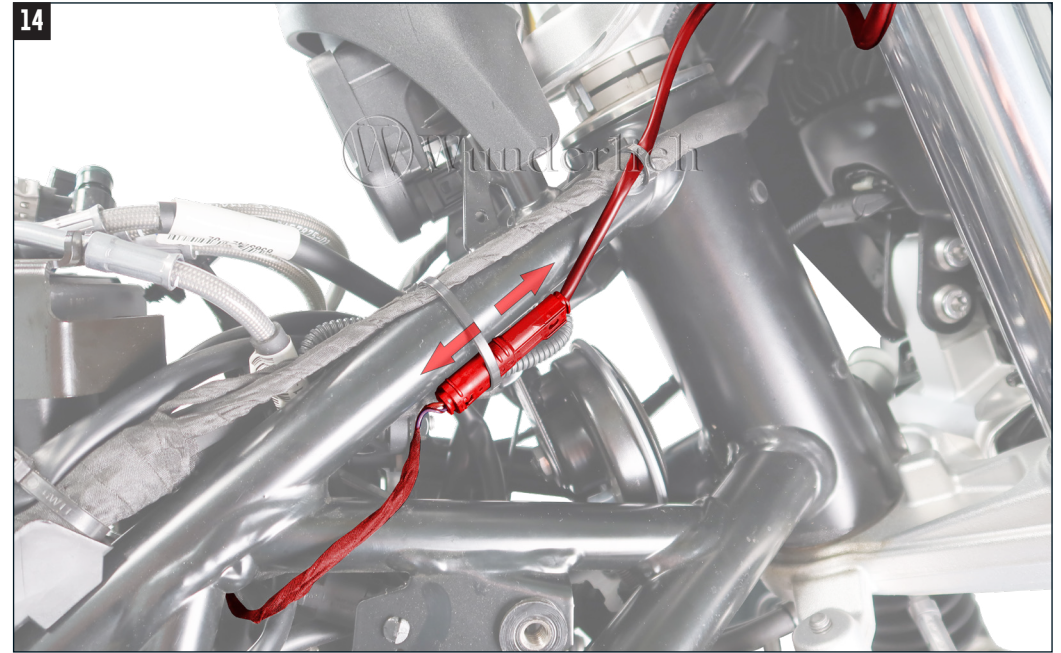
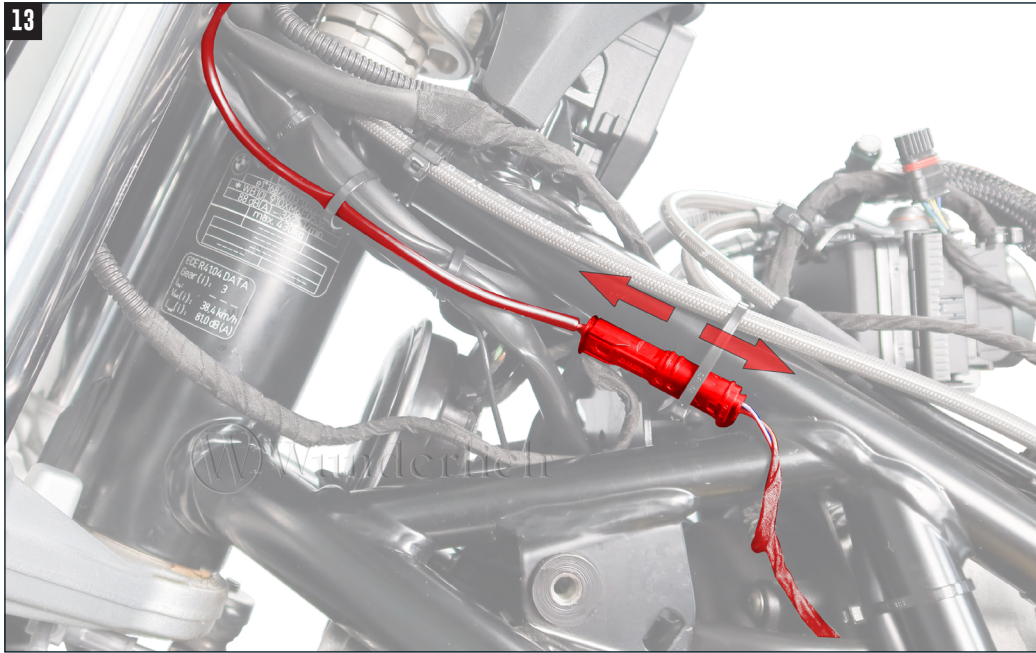



Vor dem Befestigen des Scheinwerfers am Motorrad muss er ausgerichtet werden. Das spätere Ausrichten ist nur in sehr geringem Maße möglich.
Before attaching the headlight to the motorcycle, it needs to be aligned. Later alignment is only possible to a very limited extent.
Avant de fixer le phare sur la moto, il faut l'aligner. Un alignement ultérieur n'est possible que dans une mesure très limitée.



VERLEGEBEISPIEL

Installation example | exemple d'installation | ejemplo de instalación | Esempio di installazione



Vor der Installation, müssen alle Meldungen aus dem Fehlerspeicher gelöscht bzw. behoben werden.

Before installation, all messages from the error memory must be deleted or rectified.

Avant l'installation, tous les messages de la mémoire des erreurs doivent être effacés ou rectifiés.

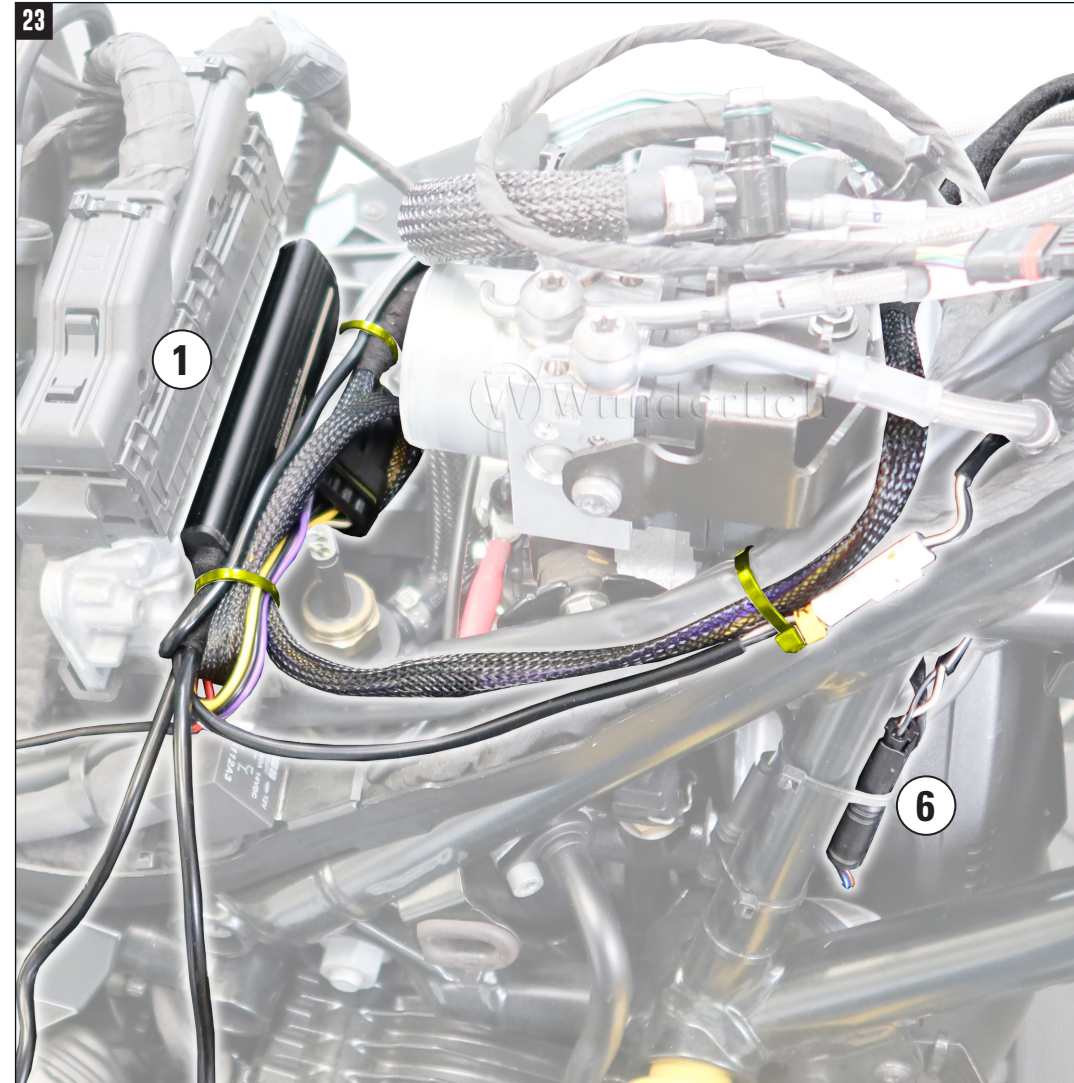
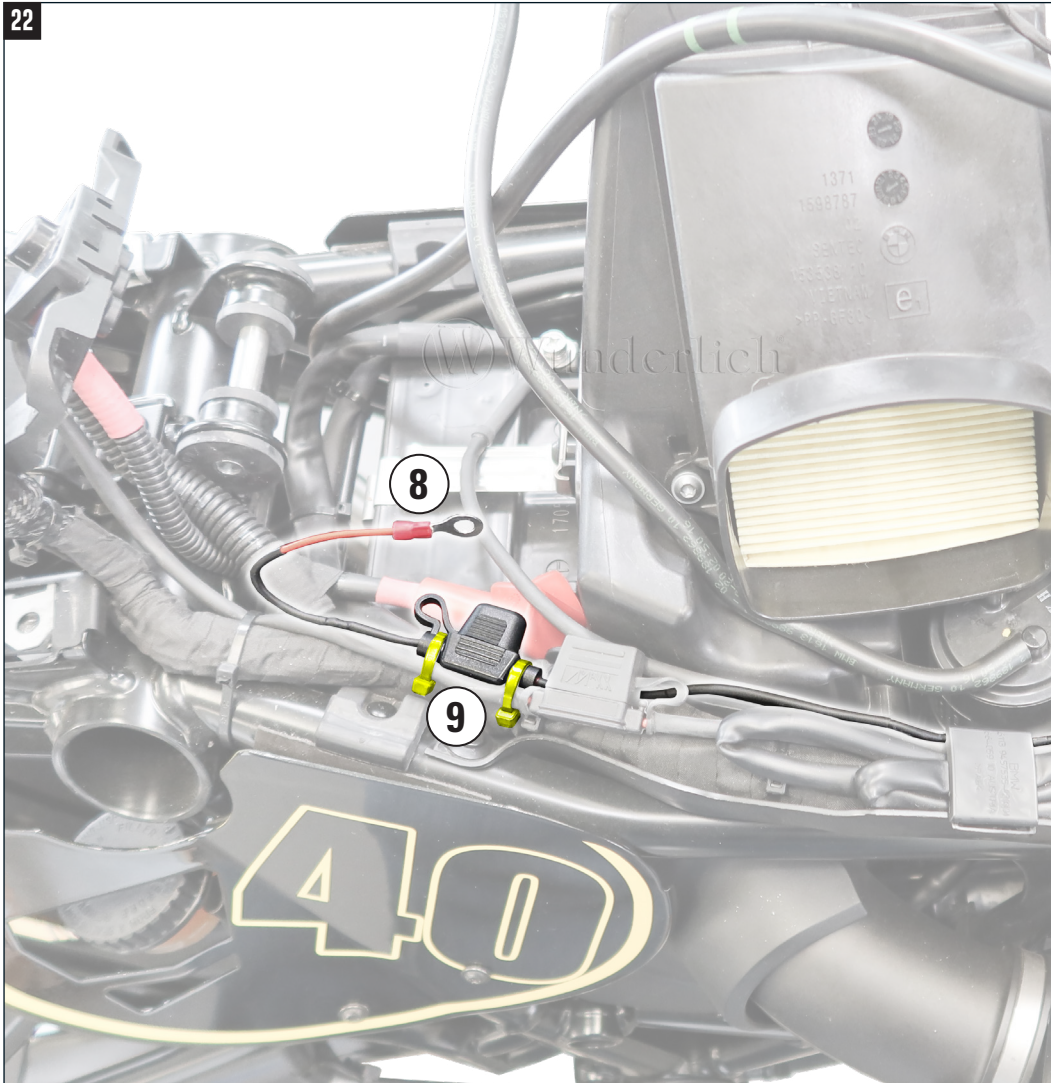

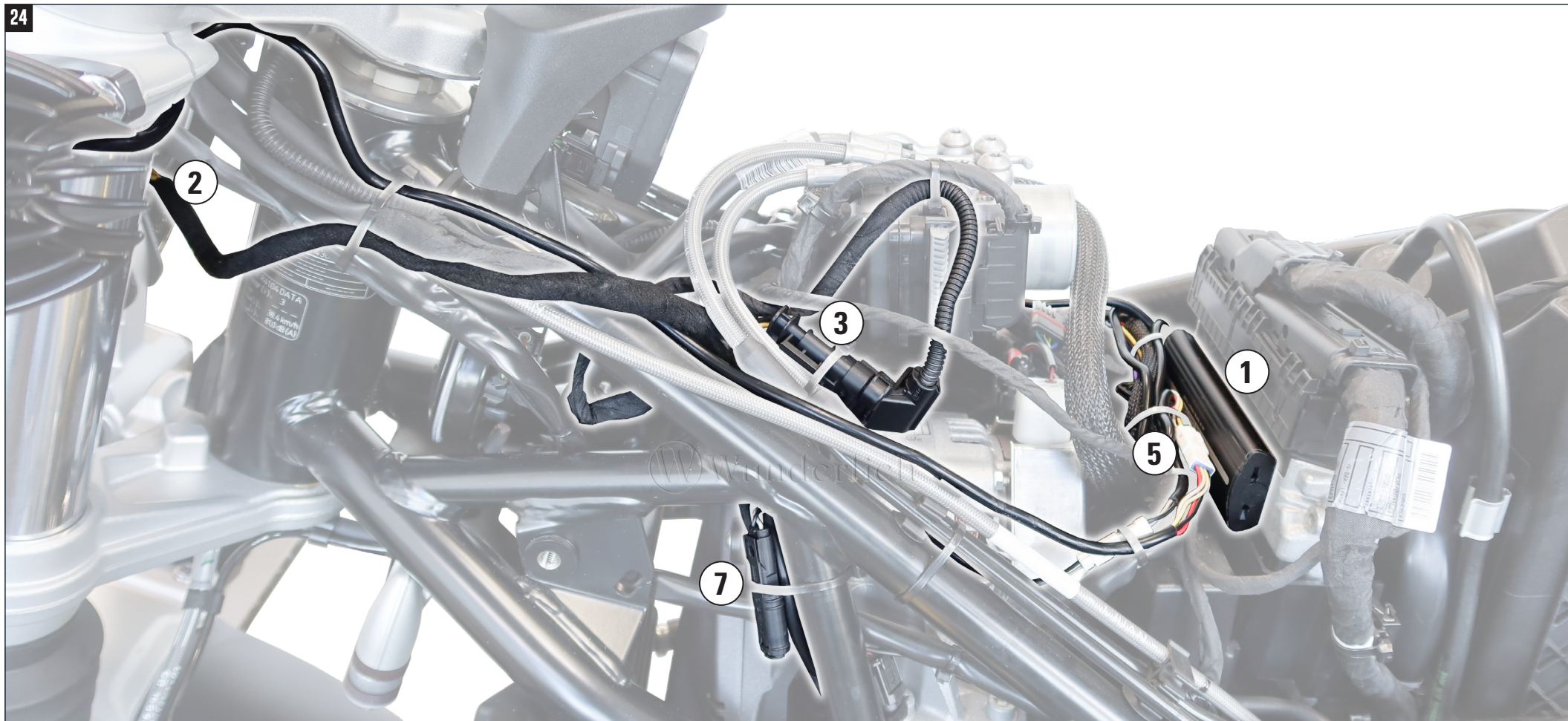

Bei den Bildern 22-24 handelt es sich um ein Verlegebeispiel. Es zeigt, wie der Kabelbaum der Dayron Scheinwerfer verlegt werden kann. Die Verlegung muss nicht eins zu eins übernommen werden. Wichtig ist der korrekte Anschluss der Steckverbindungen und des Kabels an die Batterie. Es muss darauf geachtet werden, keine Kabel zu beschädigen oder einzuklemmen.

The pictures 22-24 are an installation example. It shows how the wiring harness of the Dayron headlights can be laid. The installation does not have to be done one to one. Important is the correct connection of the connectors and the cable to the battery. It's important to take care, not to damage or pinch any cables.

Les images 22-24 sont un exemple de pose. Il montre comment le faisceau de câbles des projecteurs Dayron peut être posé. Il n'est pas nécessaire de procéder exactement de la même manière. Il est important que les connecteurs et le câble soient correctement raccordés à la batterie. Il faut faire attention à ne pas endommager ou coincer les câbles.

KABELBAUM

wiring harness | faisceau de câbles | mazo de cables | cablaggio

